

FORM PS1



Application for building consent Installation of solar water heating systems

Council:

Installer making application:
(Suitably qualified solar water heating system installer)

Address of installer:

Telephone number of installer:

Product and model number installed:

Supplier of product:

Craftsman plumber:

Address of property on which installed:

Property description: Lot: DP:

Owner of property on which installed:

This building is fitted with smoke detectors as per the G12 code requirements Yes No

Confirmation from the installer that:

- The system will be installed such that the requirements of the New Zealand Building Code have been met.
- Plumbing work has been installed to meet the requirements of standard AS/NZS3500.4.
- The system described will be installed on a dwelling on the named property according to the Code of Practice for Manufacture and Installation of Solar Water Heating Systems in New Zealand.
- A check will be made by a suitably qualified person to ensure that the system is located over suitably sound load bearing walls and strengthening of roof framing will be undertaken according to the guidelines provided by the system supplier and meets the requirements of Approved Document B1 of the New Zealand Building Code. The installation will be undertaken in terms of manuals and instructions from the product supplier
- The product supplier is a Solar Industries Association Accredited Supplier.
- The installer has been appropriately trained in the installation of the named product by the product supplier and operates under that supplier's accreditation.
- A tempering valve will be installed.
- The installer is covered by a current Professional Indemnity Insurance Policy to a current value of \$2,000,000.

The installer will provide clear sketch drawings showing the layout of the system and position with regard to roof framing and sound load bearing walls. Any strengthening required will be specified.
The seismic restraint system is to be shown on each application.

Installer signature: Date:

ROOF STRUCTURE FORM



Building Consent No:

Site plan with North orientation provided

Floor plan with cylinder location, collector location and smoke alarms positions provided.

Roof pitch: Degrees

Roof material:

ROOF STRUCTURE DETAILS

roof purlins	mm x	mm @	mm centres
truss intermediates	mm x	mm	
truss centres	mm x	mm @	mm centres
truss base cross brace	mm x	mm	

NOTES:

.....

.....

.....

.....

.....

.....

.....

.....

ECOGISE COMPONENT LAYOUT

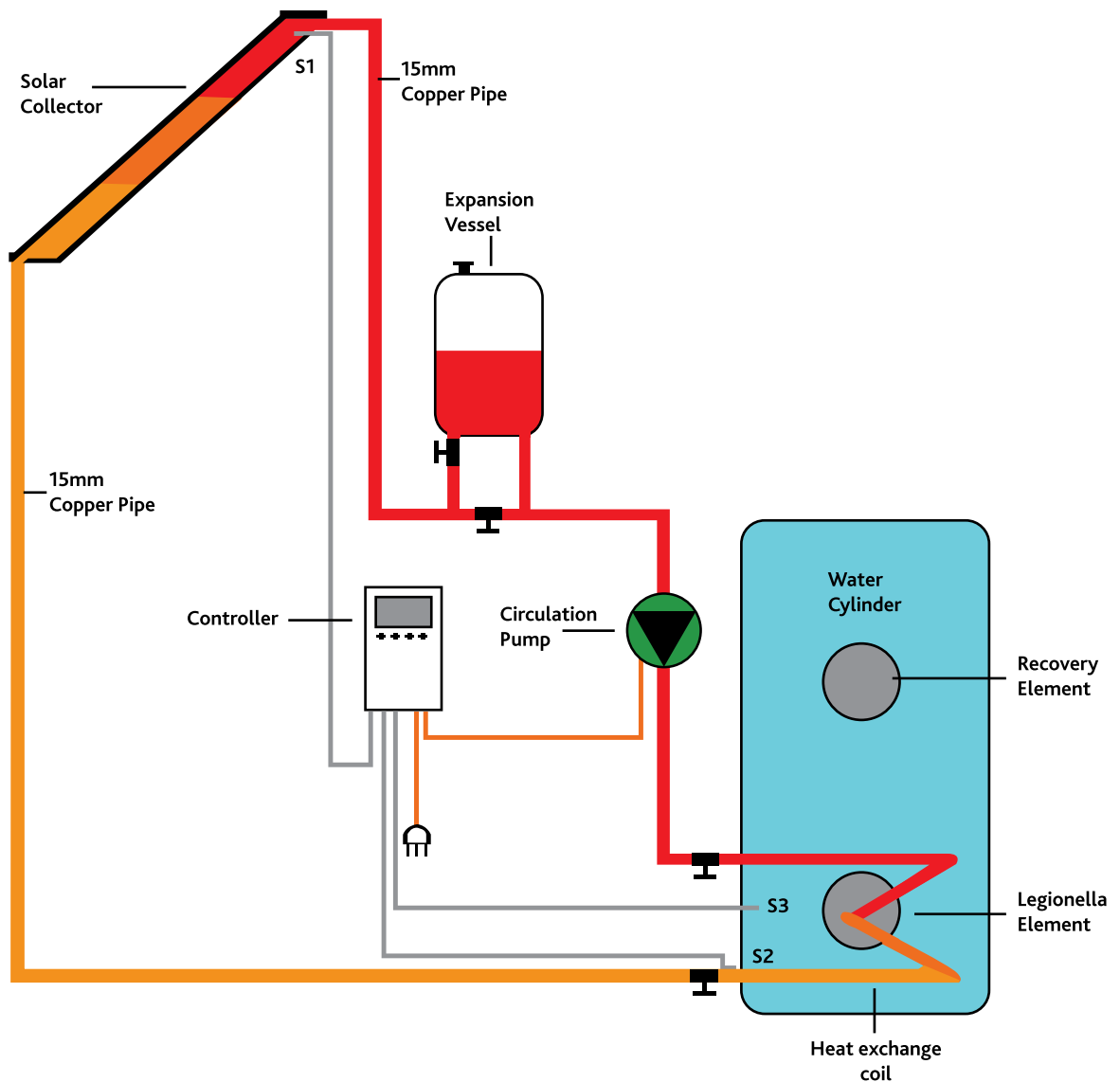

- This commonly installed ecogise system is designed for standard installations of 1 or more collector panels, facing north or within 90° of north.
- This system design is suitable for low, medium and mains pressure.
- This is a pumped, closed loop system with a heat exchange coil within the water cylinder.
- A quick recovery element in the top third of the water cylinder will top up water temperature as required.
- A legionella prevention element in the bottom of the cylinder is activated by the controller, as required.
- The expansion vessel allows for fluid expansion, release of pressure and removal of air from the system.

LOW PRESSURE VALVE DIAGRAM



**VALVE CONFIGURATION SAME FOR WET-BACK INSTALLATION
WET-BACK MUST BE OPEN VENTED**

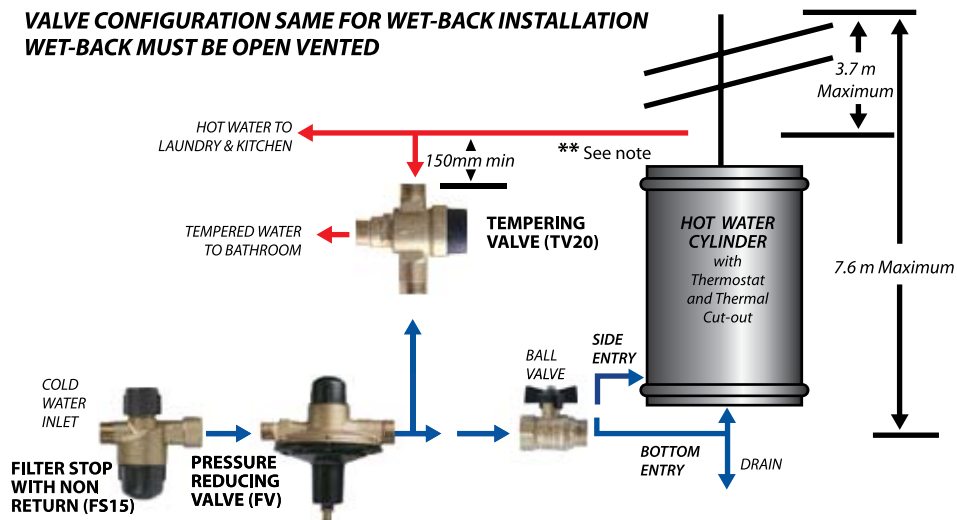

Note: ** 1.0m minimum copper pipe length from cylinder to Tempering Valve

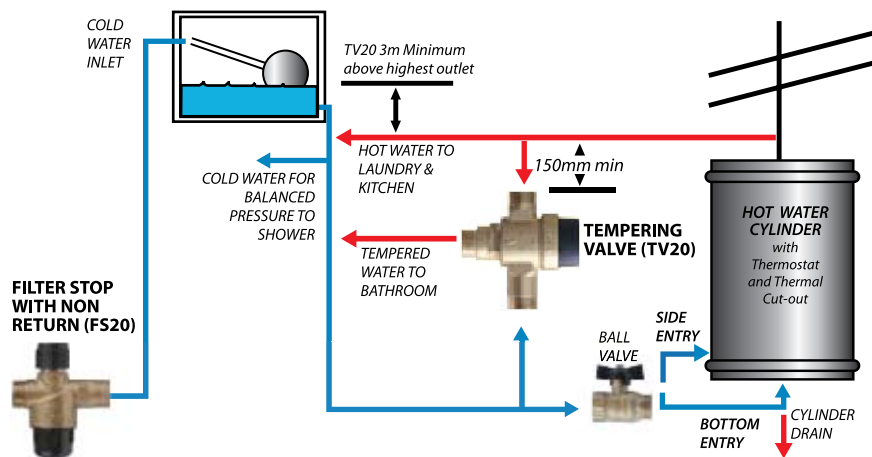

MEDIUM PRESSURE VALVE DIAGRAM

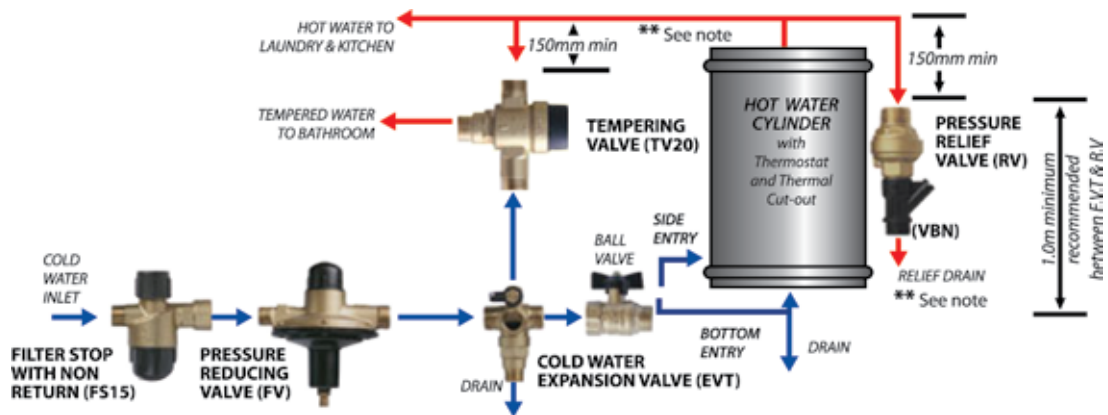

Notes:

* If the drain exceeds a factor of 12 as a combination of length in meters and number of bends (e.g. 7 metres & 5 bends) we recommend the installation of an SVB vacuum break.

** 1.0m minimum copper pipe length from cylinder to Tempering Valve

MAIN PRESSURE VALVE DIAGRAM



PLUMBING INSTALLATION

Plumbing the potable water

All plumbing installations of ecogise solar water heating systems are to be carried out as per the current New Zealand plumbing standards and regulations. This includes all pipe work, valves, restraints, potable water, connections, penetrations, consents etc.

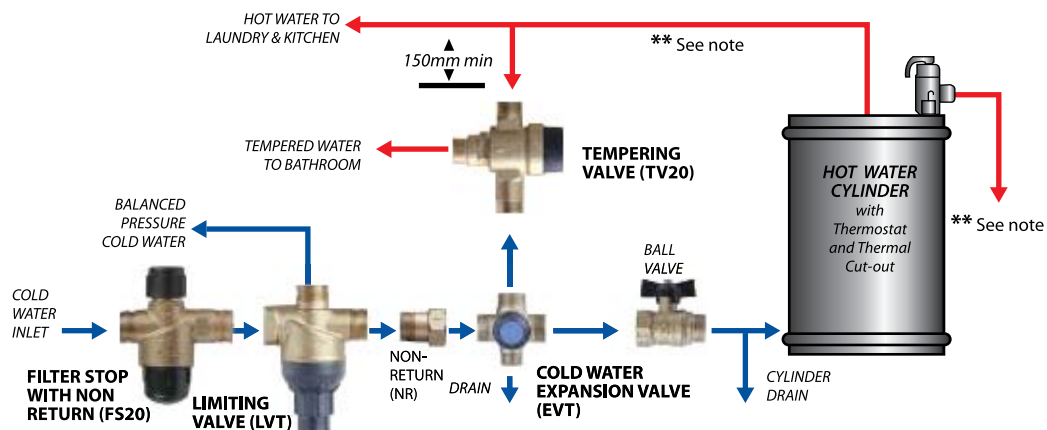

Notes:

* If the drain exceeds a factor of 12 as a combination of length in meters and number of bends (e.g. 7 metres & 5 bends) we recommend the installation of an SVB vacuum break.

** 1.0m minimum copper pipe length from cylinder to Tempering Valve

FIXTURES & FITTINGS



All ecogise installations must be carried out by an authorised ecogise installer in accordance with G12/AS2 and AS/NZS 3500.4.

When installing solar water heating systems on the roofs of homes and buildings, great care must be taken to prevent ingress of water within the building and damage to the roof integrity. The system also needs to be well fixed to prevent the wind as well as the systems own weight from removing it from its fastenings.

Our fixings and roof penetrations have been designed and perfected over the last 30 years so that they ensure there is no water ingress, there is no load on the roof cladding, they more than exceed the roof loading requirements and they are aesthetically pleasing.

ecogise do not have a roof mounted cylinder system, but we still specify that our 2.4m x 1.2m solar collectors have six fixings per collector.

No alteration is to be made to the existing structure of the roof and if necessary we recommend adding dwangs to assist fixing at the time of installation.

It is recommended that the collector be spread over two trusses and that they are mounted with adequate clearance for rain water to pass beneath the collector.

ecogise fixtures and fittings meet the acceptable solutions G12/AS2 and have patents pending on their design.

Wind & corrosion zone - please tick the appropriate boxes.

Wind zone: R1
R2

Corrosion zone: Z1
Z2
Z3
Z4

ROOF PENETRATIONS



ecogise have two patented roof penetrations for flat and curved roofing material. As well as a rubber seal, neutral curing silicon is used to ensure that they are water tight. Piping is connected above and below

the roof cladding with a hemp or rubber sealing nut. The roof penetration is placed at the high point of the roof cladding. Neutral material is used between the penetrations and the roof cladding.

STANDARD MOUNTING SYSTEM



Solar water collector mounting system for pitched roofs.

Each 2.4m x 1.2m solar collector is held in place by 6 mounting brackets. If the panel is mounted onto a pitched roof of 20° or more, one of these three bracket types is used, depending on the roof cladding (Fig. 1).

Neutral curing silicon is used on each penetration.

Neutral material is used between each bracket and the roof cladding to separate the materials.

Tek bolts on each mounting bracket penetrate the roof pulins or dwangs by at least 50mm.

Brackets are powder coated to match roof cladding colour.



Close up of a mounting bracket fixed to a corrugated iron roof.

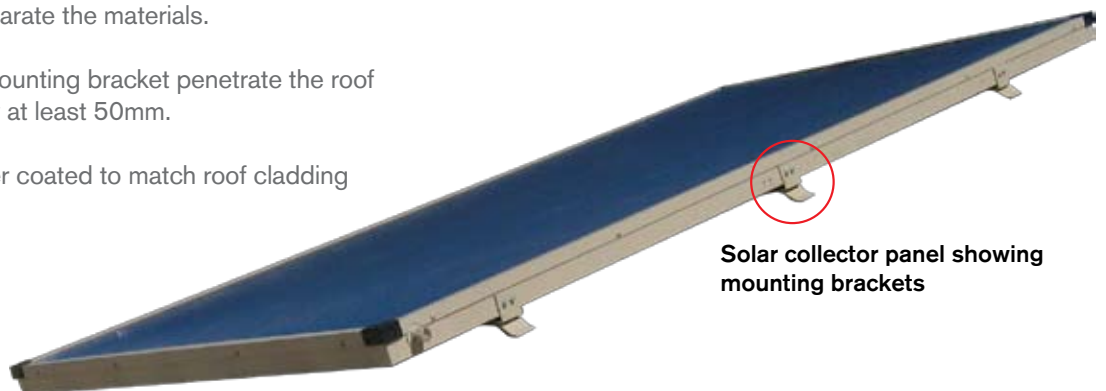

Solar collector panel showing mounting brackets

Fig. 1 Mounting brackets for various roof types

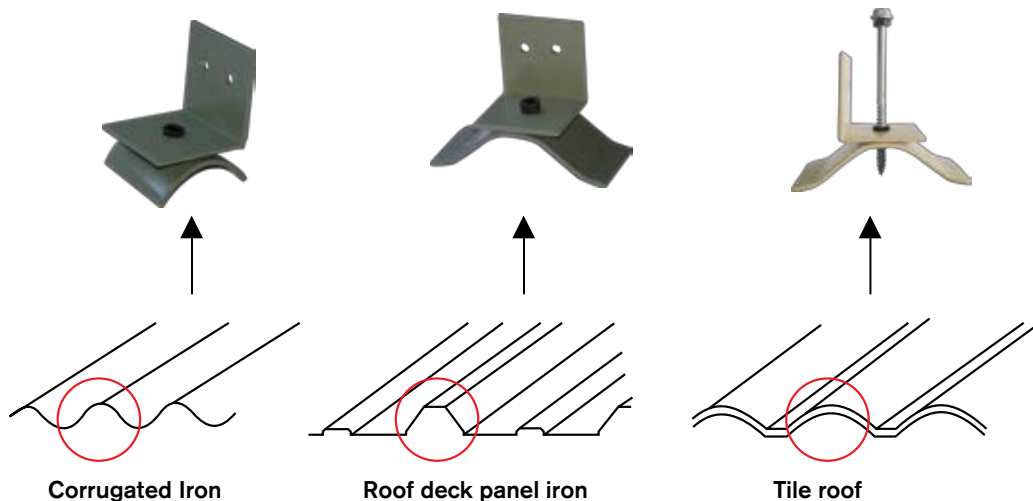

STANDARD MOUNTING SYSTEM



Solar water collector mounting system for flat roofs (or roofs with less than 20° pitch) requiring an extension rod.

Each 2.4m x 1.2m solar collector is held in place by 6 mounting brackets. If the panel is mounted onto a flat roof, or a roof with less than 20° pitch, the panels will need to be pitched up with extension rods (Fig 2).

The extension rod is a piece of extrusion cut to the required length to provide optimum angle for the collectors. It connects to a roof mounted bracket at one end (Fig. 3), and has a fitting that is screwed to the top edge of the collector panel at the other (Fig. 4).

On the lower edge of the collector panel, hinged mounting brackets are used. These have the same shape as the standard brackets shown in Fig 1 (to fit various roof types) but the part that fixes to the collector panel is hinged to allow for the pitch of the panel (Fig. 5).

Neutral curing silicon is used on each penetration.

Neutral material is used between each bracket and the roof cladding to separate the materials.

Tek bolts on each mounting bracket penetrate the roof pulins or dwangs by at least 50mm.

Brackets are powder coated to match roof cladding colour.

Fig. 2 Extension rod

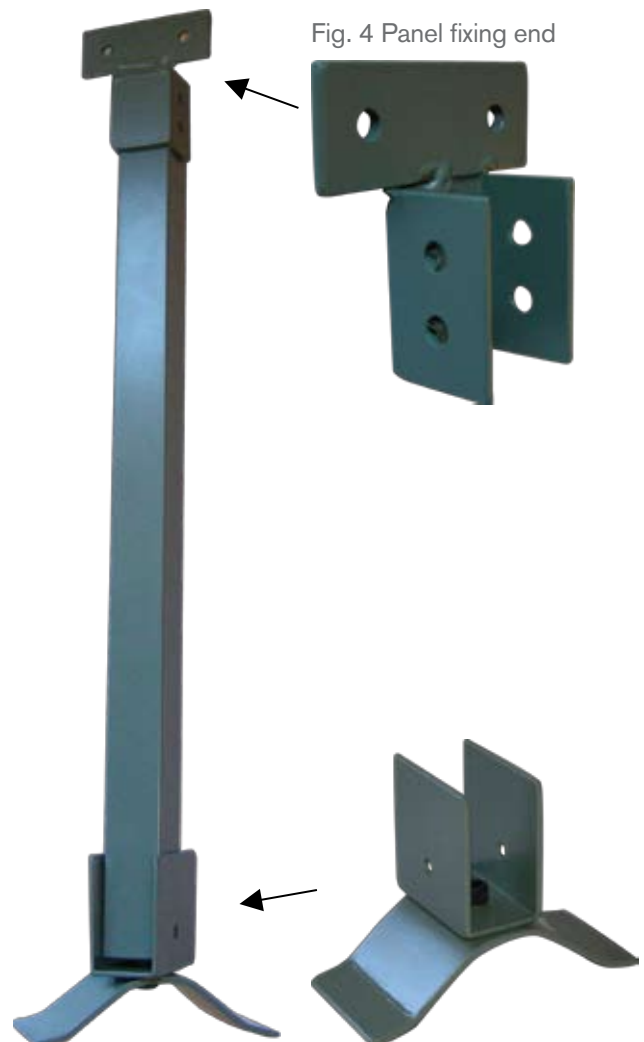

Fig. 3 Mounting bracket



Fig. 5 Hinged mounting bracket

SOLAR WATER HEATING SYSTEM SPECIFICATIONS



- Solar Collectors have a gross weight of 40 kg per panel when full.
- Gross collector area per panel is $2.4 \times 1.2\text{m} = 2.8\text{m}^2$
- All pipe work will be 15mm x 1.02mm semi hard copper and lagged with 13mm closed cell polymer ($R = 0.3$) covered with tin-foil tape if exposed to UV light.
- All electrical roof penetrations will be sealed by a Mini-Dektite fitting.
- All plumbing and mounting penetrations will be as per SIA accredited 'ecogise solar hot water heating installation manual' (Patents pending).
- Neutral curing silicon is used on all roof penetrations to ensure a watertight seal.
- All installations are separated from contact with metal cladding by non-metallic, non-corrosive padding.
- All the fixing bracket bolts must penetrate the truss, purlin or dwang by at least 50mm.
- All fixing, brackets, screws and bolts are galvanised. Any additional fixings used by the installer on steel cladding must also be galvanised.
- Legionella protection is via the lower electrical element in the water cylinder and is controlled by the solar controller, set to come on once a week for a set period of time.
- Frost protection is via a closed loop system using glycol and protected to below -25°C .
- Expansion of the glycol is handled by the ecogise expansion tank and overflow bottle. There is no potential for dumping of fluid due to over-temperature conditions.



A Mini-Dektite fitting

All ecogise systems are tested and approved to AS/NZS2712:2007 standards.

FORM PS3



Model Producer's Statement PS3 Installation of Solar Water Heating Systems.

Council:

Building Consent No:

Producer Statement issued by:

Address of installer:

Telephone number of installer:

Product and model number installed:

Supplier of product:

Craftsman plumber:..... Registration No

Registered electrician: Registration No

Address of property on which installed:

Location of installation:

Owner of property on which installed:

Property description: Lot: DP:

• The system has been installed such that the requirements of the New Zealand Building Code have been met. Plumbing work has been installed to meet the requirements of standard AS/NZS3500.4.

Craftsman Plumber Signature: Date:

- The solar water heating system described above has been installed on a dwelling on the named property according to the Code of Practice for Manufacture and Installation of Solar Water Heating Systems in New Zealand and the requirements of the Building Consent.
- The system has been located as shown on the drawings provided with the Building Consent Application. A check has been made by a suitably qualified person to ensure that the system is located over suitably sound load bearing walls and strengthening of roof framing has been undertaken according to the guidelines provided by the system supplier and meets the requirements of Approved Document B1 of the New Zealand Building Code.
- The installation has been undertaken in terms of manuals and instructions from the Product Supplier who is a Solar Industries Association Accredited Supplier.
- I certify that I have been appropriately trained in the installation of the named Product by the Product Supplier and operate under that Supplier's accreditation. As an independent solar water heating system installer I am covered by a current Professional Indemnity Insurance Policy to a current value of \$2,000,000
- The Installer will provide clear sketch drawings showing the layout of the system and position with regard to roof framing and sound load bearing walls. Any strengthening required will be specified. The seismic restraint system is to be shown on each application.

Installer signature: Print name:

Date:

WATER CYLINDER RESTRAINTS DIAGRAM



Extra centre strap for water cylinders exceeding 200 litres.

Storage water cylinder to be restrained with 25 x 1mm galvanized steel straps tensioned when fixed in place.

Straps to be fixed to wall with:

- 8mm coach screw with 30 x 2mm thick washer or
- 20 x 2.5mm thick washers.

Screw to penetrate timber framing by a minimum of 50mm.

Example A

50 x 50mm vertical blocking of water heater, fixed to wall framing with 1 no. 100 x 3.75mm nail @ 600 centers.

Example B

Light timber frame wall complying with NZS 3604

