

# IllumiBrite Greenway™ Solar LED Lighting Solution

The eco-smart choice  
for safety and security

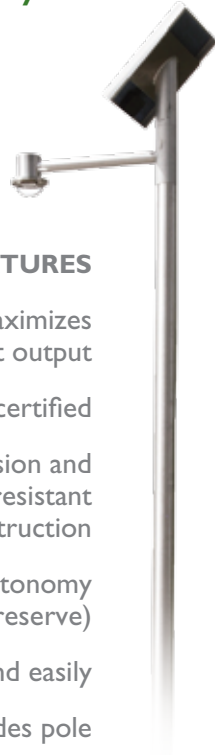

## FEATURES

Max Lite™ reflector maximizes  
LED light output



Dark-Sky certified

Corrosion and  
vandal-resistant  
construction

5 days of autonomy  
(battery reserve)

Installs quickly and easily

Complete system includes pole

## SPECIFICATIONS

System voltage	12 VDC
Batteries	100 AH Gel Cell – maintenance free
Lamp type	LED
Mounting height	12-15 feet
Light color temp	5100K
Lamp life span	100,000 hours
Operating temp	-20 F to +120 F
Operating hours	Programmable, 6 hr to dusk to dawn
Fixture type	Greenway® series
Pole included	20 ft direct burial
System colors	powder coated black or bronze; optional colors available

Solar panel specifications may vary by manufacturer

Model	Solar Array	Solar array dimensions	Panel power (output amps)	System weight with pole
Greenway™ 40	40 watt panel	30" x 19.75"	2.37 amp @ 12V	225 lb.
Greenway™ 80	80 watt panel	46.75" x 20.8"	4.55 amp @ 12V	250 lb.
Greenway™ 130	130 watt panel	59.02" x 26.06	7.16 amp @ 12V	300 lb

**Sol**® 

Reliable. Renewable. Remarkable.

**ecogise**   
LOVIN THE POWER

[www.ecogise.co.nz](http://www.ecogise.co.nz)

# IllumiBrite Greenway™ Solar LED Lighting Solution

The eco-smart choice  
for safety and security

## Light Output:

- Solid State LED – 192 LED's per fixture
- Light color: 5100 K
- CRI Index 80
- Lamp Rated Wattages: 11.8 or 18.9
- LED Life Expectancy: 100,000 hours
- IDA Dark Sky Certified
- LED pack produces rectangular light pattern

## Fixture:

- Die cast corrosion resistant
- Power-coated paint finish
- Condensation prevention
- Polycarbonate Hemi Dome lens
- "O" Ring Sealed
- Dimensions: 5.25" x 9" x 11"
- Weight: 6 lbs.

## Support Arm:

- Length: 26.25 inches
- Grade "A" Corrosion Resistant Aluminum
- Weight: 12 lbs.

## Battery Box:

- 8.3" x 12.9" x 16"
- Grade "A" Corrosion Resistant Aluminum
- Weight: 9.5 lbs.

## Battery:

- Gel Cell – No maintenance
- 100 amp hour resistant
- Weight: 62 lbs.

## Direct Burial Pole:

- 4" I.D. Schedule 40 straight aluminum pole
- 20' direct burial
- Powder-coated to match system
- Weight: 68 lbs.

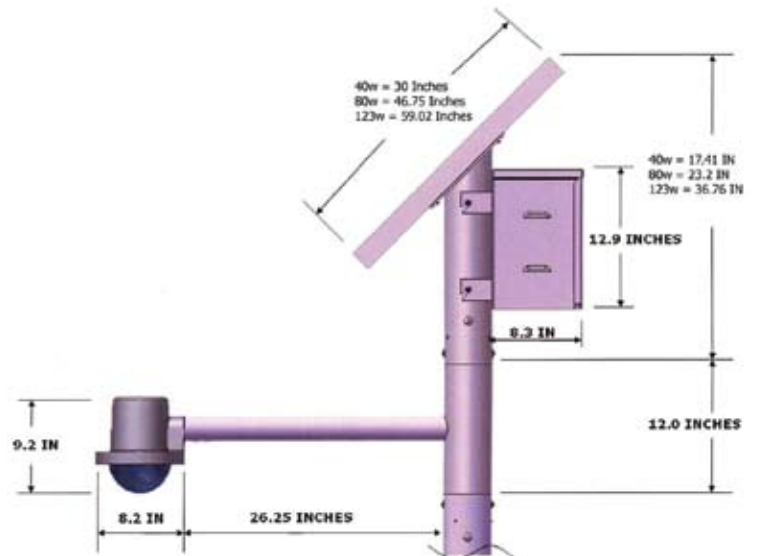
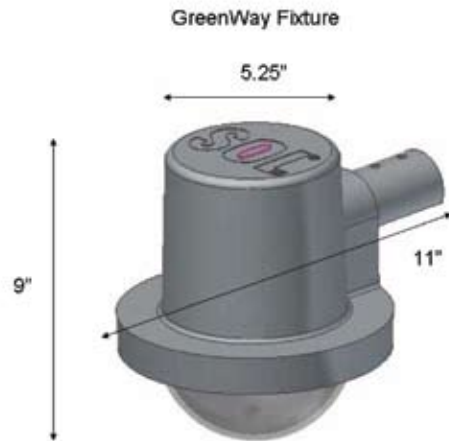

  
**ecogise**™  
LOVIN THE POWER

22 Quarantine Road, Annesbrook  
PO Box 1373 | Nelson 7040 | New Zealand  
Ph: 0800 4 326 4473 | Fx: 03 547 1324  
[www.ecogise.co.nz](http://www.ecogise.co.nz)